

**MANUAL  
FOR  
SURFACE FINISHING EQUIPMENT  
TECHNOVIBE B-SERIES  
BOWL VIBRATOR**

*(September 2001)*

***B.V. Products (Australia) Pty. Ltd.  
14 Brett Drive  
Carrum Downs  
Victoria 3201  
AUSTRALIA***

***Tel: +61 3 9775 0898***

***Fax: +61 3 9775 0897***

***Website: [www.bvproducts.com.au](http://www.bvproducts.com.au)***

***Email: [mail@bvproducts.com.au](mailto:mail@bvproducts.com.au)***

***NOTE: B.V. Products (Australia) Pty. Ltd. reserves the right to alter details and specifications, without notice, in the interests of better performance and/or greater reliability in the operation of equipment.***

# **CONTENTS**

<b>1</b>	<b>INTRODUCTION</b>	<b>3</b>
<b>2</b>	<b>WARRANTY</b>	<b>4</b>
<b>3</b>	<b>TECHNICAL SPECIFICATIONS</b>	<b>5</b>
3.1	<i>Vibratory Motor</i>	5
3.2	<i>Dimensions</i>	6
3.3	<i>General</i>	7
<b>4</b>	<b>INSTALLATION</b>	<b>8</b>
4.1	<i>Site Location</i>	8
4.2	<i>Electrical Connections</i>	8
4.3	<i>Water Supply</i>	8
4.4	<i>Drainage System</i>	9
<b>5</b>	<b>OPERATION</b>	<b>10</b>
5.1	<i>General Information</i>	10
5.2	<i>Lower Weight Adjustments</i>	10
5.3	<i>Upper Weight Adjustments</i>	10
5.4	<i>Auxiliary Weights</i>	10
5.5	<i>Unloading and Separation</i>	11
5.6	<i>Water Flow and Compound Dosing Systems</i>	11
5.7	<i>Processing</i>	11
5.8	<i>Media Changes</i>	12
5.9	<i>Operating the Machine with a Variable Speed Controller (if supplied)</i>	12
<b>6</b>	<b>MAINTENANCE</b>	<b>13</b>
6.1	<i>General Information</i>	13
6.2	<i>Motor</i>	13
6.3	<i>Fastenings</i>	13
<b>7</b>	<b>SUPPLIES, SPARES AND SERVICE</b>	<b>14</b>
<b>8</b>	<b>DRAWING – Pictorial General Assembly &amp; Sound Lid</b>	<b>15</b>
<b>9</b>	<b>MOTOR DETAILS</b>	<b>16</b>

## **1 INTRODUCTION**

Congratulations on your purchase of a B.V. Products TechnoVibe B-Series bowl vibrator. This machine has been carefully engineered to withstand the severe conditions that are imposed by the low frequency vibration and heavy impact loading that is necessary in the application of vibratory finishing in mass production processes. Provided the basic instructions in this manual are observed, the machine will provide its owner with years of trouble free service for a minimum of maintenance effort.

## **2 WARRANTY**

All equipment that is manufactured by B.V. Products (Australia) Pty. Ltd. is warranted against faulty workmanship and/or materials for a period of 6 months from the date of supply. The work chamber (bowl) of TechnoVibe B-Series machines is warranted for a period of twelve (12) months from the date of supply. However, B.V. Products (Australia) Pty. Ltd. offers an extended written warranty period against premature wear of two (2) further years (this excludes separation screen/unload door parts).

All warranties are dependant on the machine being installed, operated and maintained in accordance with instructions provided by B.V. Products (Australia) Pty. Ltd. - or their accredited agents.

The work chamber warranty is also dependant on the customer's exclusive use of media and compounds supplied by B.V. Products (Australia) Pty. Ltd. - or their accredited agents. Furthermore, the extended work chamber warranty will only be offered to purchasers who use processes and consumables supplied or approved by B.V. Products (Australia) Pty. Ltd. or its nominated representatives.

Proprietary items that are not manufactured by B.V. Products (Australia) Pty. Ltd. (electrical control gear, and compound metering pumps, for example), are excluded from the general warranty. Such items are covered by the individual manufacturer warranties - as offered to B.V. Products (Australia) Pty. Ltd.

### 3 TECHNICAL SPECIFICATIONS

#### 3.1 Vibratory Motor

Your TechnoVibe B-Series bowl vibrator is fitted with a powerful, flange-mounted vibratory motor (see Table 1). The motor is designed to operate from either 220/240 Volts or 385/415 Volts, 3-phase, 50-60Hz supply. Voltage configuration is factory set by arrangement of connections in a junction box mounted on the side of the motor casing. Voltage specification is (plus/minus) 10%.

Model	Motor Type	Motor Power (W)	
		Input	Output
<b>TBV1B</b>	Invicta SFL15-3/4	355	175
<b>TBV3B</b>	Invicta SFL20-5/4	450	250
<b>TBV4B</b>	Invicta SFL25-14/4	675	500
<b>TBV7B</b>	Invicta SFL30-25/4	1135	1150
<b>TBV12B</b>	Invicta SFL30-25/4	1135	1150
<b>TBV18B</b>	Invicta SFL50-45/4	3740	3350

Table1: TechnoVibe B-Series Bowl Vibrator/Motor Combinations

3.2 Dimensions

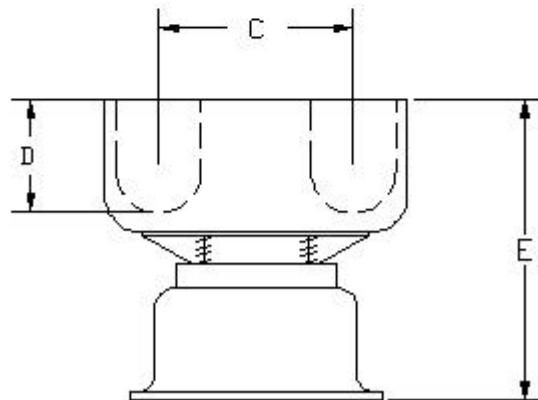
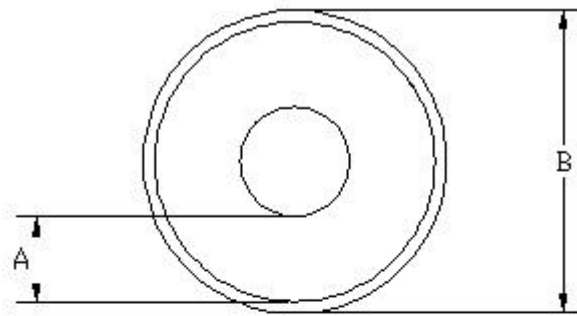

Model	A	B	C	D	E
TBV1B	150	615	450	200	745
TBV3B	250	760	500	270	840
TBV4B	280	820	500	310	870
TBV7B	325	995	610	400	945
TBV12B	380	1400	900	450	1050
TBV18B	510	1660	1220	620	1260
TBV25B	510	1660	310	720	1360

Table 2: TechnoVibe B-Series Dimensions (mm).

### 3.3 General

<b>Model</b>	<b>Capacity (L)</b>	<b>Bowl Volume (L)</b>	<b>Weight (kg)</b>
<b>TBV1B</b>	<b>35</b>	<b>40</b>	<b>60</b>
<b>TBV3B</b>	<b>84</b>	<b>100</b>	<b>80</b>
<b>TBV4B</b>	<b>120</b>	<b>135</b>	<b>130</b>
<b>TBV7B</b>	<b>200</b>	<b>225</b>	<b>230</b>
<b>TBV12B</b>	<b>336</b>	<b>470</b>	<b>580</b>
<b>TBV18B</b>	<b>540</b>	<b>650</b>	<b>900</b>
<b>TBV25B</b>	<b>750</b>	<b>870</b>	<b>1000</b>

Table 3: TechnoVibe B-Series General Specifications

## 4 INSTALLATION

No special area is necessary for the installation of your TechnoVibe B-Series bowl vibrator. As the induced vibration is in the horizontal plane and the work chamber is mounted on vertical coil springs, vibration and impact loading is isolated from the base so that there is no movement transferred through to the floor. Where the floor may not be perfectly level however, it is recommended that the base is bolted or clamped down.

Operational facilities are those normally found in any commercial location : i.e. mains water supply, drainage system, 220/240 Volts single phase, and 385/415 Volts, 3 phase electrical supplies.

### 4.1 Site Location

Your TechnoVibe B-Series bowl vibrator should be installed on a firm and level surface. The site selected should have facilities for connection to a water supply and for outlet flow to an effluent settling tank or drainage system.

#### **CAUTION !**

**AFTER LOCATING THE MACHINE ON SITE AND BEFORE MAKING ANY ELECTRICAL SUPPLY CONNECTIONS TO THE MACHINE, ENSURE THAT THE TRANSIT LOCKING BOLTS AND BLOCKS IF FITTED ARE REMOVED FROM LOCATION BETWEEN THE BOWL AND BASE.**

**FAILURE TO REMOVE THE TRANSIT LOCKING BOLTS AND BLOCKS COULD RESULT IN CONSIDERABLE DAMAGE IF THE MACHINE IS STARTED.**

### 4.2 Electrical Connections

Electrical supply to your TechnoVibe B-Series bowl vibrator is via a separate control panel. Depending on the exact specification of the machine, this may incorporate an electronic Variable Speed Controller (see *Operating the Machine with a Variable Speed Controller*).

Connection of the control panel to the machine is to a terminal box mounted on the side of the machine's base.

All electrical connections should be made by a qualified electrician and in accordance with the Electrical Circuit Diagram supplied with your particular control panel. If in doubt, consult a B.V. Products technician.

**IMPORTANT! THE MACHINE MOTOR MUST ROTATE IN THE CORRECT DIRECTION TO GIVE THE PROPER PROCESSING ACTION.**

This can be checked by placing a coin on the outer edge of the top of the machine's centre tube. If the coin moves to the centre of the machine the motor direction is correct. If the coin moves outwards and drops into the work chamber the direction of motor rotation is incorrect. This can be corrected by interchanging any two of the electrical phases inside the machine's electrical terminal box.

### 4.3 Water Supply

Water supply to your TechnoVibe B-Series bowl vibrator is connected via a "Tee" fitting mounted on the machine's base. 13 mm (1/2") flexible hose and worm drive hose clamp

are recommended for use at this point. The arrangement of water supply includes a tap so that the rate of flow into the machine can be varied. Typical flow rates are between 1 and 2 L/min. - but vary according to the type of process in operation.

#### **4.4 Drainage System**

Effluent discharge from your TechnoVibe B-Series bowl vibrator is through a slotted drain at the bottom of the work chamber. This drain leads out of the bowl to a ball valve. The valve provides a facility for the operator to use a captive water process when required i.e. closing the valve. A captive process is often employed as a cost saving method when powder compounds are used to assist the finishing operation.

Effluent discharge from your TechnoVibe B-Series bowl vibrator consists mainly of water, and - depending on the process in operation - can carry quite a large variety of solids in suspension. Solids will be in the form of metal fines from the parts being processed and abrasive fines, which are released as the media works on the parts. The discharge can also contain residue of liquid compounds in solution or mixture with the water.

***BEFORE THE FINISHING MACHINE DISCHARGE IS ALLOWED TO ENTER DRAINAGE SYSTEMS THAT ARE PROVIDED BY THE LOCAL AUTHORITIES FOR COMMON USE (SEWERAGE FOR EXAMPLE) THE SOLIDS MUST BE SETTLED (OR FILTERED) OUT, AND THE REMAINING FLUIDS SHOULD BE CHECKED FOR NEUTRALITY. EFFLUENT DISCHARGE MUST NEVER BE ALLOWED TO ENTER STORM DRAINS OR ANY OTHER DRAIN THAT EVENTUALLY REACHES THE TOWN WATER SUPPLY ARRANGEMENTS. IF IN DOUBT - CONSULT ENGINEERS EMPLOYED BY THE WATER SUPPLY AUTHORITIES.***

For individual machine finishing systems, a small triple pass settling tank arrangement (say 100 - 200 litres capacity depending on model) is usually sufficient to meet the requirements for discharge cleanliness. However, always remember to check with the local authorities and obtain their permission for discharge of the effluent when necessary.

For large finishing system operations, B.V. Products (Australia) Pty. Ltd. can supply effluent discharge systems that are mounted on a portable skid. These systems can provide settling, filtering and automatic pH correction, together with alarm indications for such instance as when the quality of discharge may be temporarily outside specifications of the local authority. It must be pointed out however that the regulations vary from area to area and any proposal for discharge of effluent must be presented to the proper authorities before the common line drainage systems are used.

## 5 OPERATION

### 5.1 General Information

Whilst your TechnoVibe B-Series bowl vibrator performs all the functions of a mass production surface finishing process - there are only three simple adjustments that may be required to optimise the performance for any particular type of process. These are:-

- i. Angular adjustment of the lower weight which is mounted on the vibrator motor.
- ii. Increasing or decreasing the flow of water and/or amount of compound entering the work chamber.
- iii. Adjusting frequency output of the variable speed controller (if supplied).

### 5.2 Lower Weight Adjustments

Access for adjustment of the lower weight angle requires lifting of the machine from under the base using a forklift or other similar lifting device. The angle of this weight (in relation to the butted position of the upper weight against the driving stopper) controls the length of time taken for parts being processed to make one complete run around the work chamber. For example :- lower weight is positioned directly under the upper weight (ref. angle 0 degrees) the "pitch" (helical movement of media in the work chamber) is virtually nil - whereas when the lower weight is located to "lead" the fixed position top weight by 90°, the pitch is at its maximum - and the media and parts progress around the work chamber fairly rapidly. The amount of lead angle is adjusted by loosening the weight clamping bolts and re-fixing in the desired position. Relative position of the weights can be sighted by viewing top weight through port cut in the motor housing assembly.

Similar changes to the passage of media and parts around bowl can be achieved by use of the Variable Speed Controller (if supplied). See *Operating the Machine with a Variable Speed Controller*.

Lead angle of the lower weight is also a determining factor in the amplitude of vibration. Amplitude affects the efficiency of the abrasive, or "scrubbing" action that takes place as parts are being processed. Generally, a larger amplitude produces a harsher abrading action. At 90° lead, the amplitude will normally be between 4 and 6 mm.

The effect of changing lead angle can also be observed by watching the roll (or cascade) of media in the work chamber - at 90° lead, the roll is fairly active, and will smooth off quite noticeably as the lead angle is increased. By changing the amplitude of vibration, experienced finishing machine operators can achieve a remarkable effect on the quality of finish or on the time required to complete various jobs to the required state.

### 5.3 Upper Weight Adjustments

**No upper weight adjustments are recommended on TechnoVibe B-Series bowl vibrators.**

### 5.4 Auxiliary Weights

No auxiliary weight adjustments are recommended on TechnoVibe B-Series bowl vibrators without prior consultation with a B.V. Products Technician.

### 5.5 Unloading and Separation

Once the required part surface finish has been achieved, the machine should be stopped, then switched to the unloading (reverse) mode.

In the Process mode, the vibrator motor rotates clockwise (viewed from above) In this condition the media and parts travel counter-clockwise around the bowl.

In the Unloading mode, the vibrator motor rotates in a counter-clockwise direction (viewed from above). In this condition the media and parts still travel clockwise around the bowl – but tend to cascade to the outer wall and come to the surface where they can be easily collected by hand picking.

**REMEMBER - WHEN CHANGING MODE FROM PROCESS TO UNLOAD (OR VICE VERSA) ALWAYS ALLOW THE MACHINE TO STOP FULLY BEFORE STARTING IN THE REVERSE DIRECTION.**

### 5.6 Water Flow and Compound Dosing Systems

Water flow is used in the finishing machine work chamber to wash through the media and work pieces so that the media is kept clear of metal fines and that waste material is carried out of the machine to the discharge system. Compounds are used to assist the work process in a number of ways - in cutting speed, or in polishing ability, or keeping the media clean for a few examples. Compounds are available in two forms - Powder or Liquid. Each form has particular advantages over the other.

Selection of the compound form generally depends on the operator's preference, and sometimes on the process being performed. With powder compounds, the machine outlet ball valve is usually kept closed (and the water flow is stopped when sufficient water is in the bowl) this is termed as a "closed cycle" operation, and the powder is placed in by measure.

With liquid compounds, the machine outlet ball valve is kept open (and the water flow is allowed to pass through to the discharge system) this is termed as a "flow through" operation. In flow through operation, the liquid compound can be placed into the bowl by measure (a wasteful method) but is usually controlled by injection to the bowl via a chemical metering pump, which can be mounted on the side of the machine base. Liquid compounds can also be used in a closed cycle operation if required.

### 5.7 Processing

For efficient processing of parts, the work mass (media and parts) level in the machine should be approximately 25-50 mm below the water spray nozzle. The ratio of media to parts will vary according to size and shape of the parts to be processed, as well as the delicacy and finish required. As a rule of thumb however, the media to parts ratio should be about 4:1 by volume. In the ideal condition then - every part present in the work chamber should be completely surrounded by media while it is carried around the bowl in operation. Inadequate amount of media will not allow the media movement to be correct and will allow parts to strike on each other during the processing cycle.

Media cleanliness is important - during cutting operations, the fines removed from work pieces tend to become embedded on the cutting surfaces of the media (rather like the way teeth on a file become clogged when filing aluminium). This "clogging" of the surfaces decreases the efficiency of media operation and increases times required for completion

of the work. Special compounds (powder and liquid types) are available for use to clean the media surfaces. These should be used at least once a week; or sooner if the operator experience dictates requirement.

**REMEMBER: MEDIA CLEANING COMPOUNDS ARE ACIDIC IN NATURE. OBSERVE ALL USUAL SAFETY PRECAUTIONS WHEN USING MEDIA CLEANING COMPOUNDS. PLACE MEDIA CLEANING COMPOUND INTO THE MACHINE BOWL BY MEASURE - NEVER PASS LIQUID MEDIA CLEANING COMPOUND THROUGH THE COMPOUND METERING PUMP.**

### **5.8 Media Changes**

As media carries out its work, it necessarily decreases in size, and each piece becomes progressively lighter in weight. Lighter media does not have the same cutting efficiency as heavier media, therefore as the media wears the process time required to obtain original finishes will be extended in comparison. Another problem may occur if the media size is close to the size of apertures or bores in the work being processed - worn media may become lodged. It is essential therefore that the full load of media is changed when its size has decreased to start creating these problems. The practice of topping up with fresh media is not recommended - all that this achieves is to wear out the new media more quickly than normal and introduce the lodgement problems with increased difficulty in removing the lodged pieces.

The easiest method of emptying media from your TechnoVibe B-Series bowl vibrator is to use a plastic bucket or large scoop for bailing out into a suitable larger container. Run the machine in process mode and insert the bucket against the flow of media. There is no need to push the bucket into the media mass - it will fill itself as the media runs into it.

### **5.9 Operating the Machine with a Variable Speed Controller (if supplied)**

A variable speed controller is used to control the frequency of voltage supply to the vibratory motor, and thus the frequency of vibration of the machine.

Optimum processing performance of TechnoVibe B-Series bowl vibrators is generally obtained with an operating frequency of 50 Hz. Frequencies lower than 50 (suggested minimum = 35 Hz) are useful when wishing to lessen the abrading action of standard media (for brightening parts at the end of a deburring process for example). Frequencies greater than 50 Hz (absolute maximum 55 Hz) should only be used for short periods of time.

While high frequency operation will make the media action more aggressive, it increases the centrifugal force exerted by the out of balance weights and can result in premature bearing failures by taking the bearings to a loading that is outside tolerance. When units are supplied to an area where the mains voltage supply is normally 60 Hz, the use of a variable speed controller (phase inverter) is recommended so that the machine can be operated at its optimum design frequency of 50 Hz.

**NOTE: Prior to despatch from the factory, the variable speed controller parameters will have been set-up to match the finishing machine. DO NOT ADJUST THESE SETTINGS WITHOUT FIRST CONSULTING A B.V. PRODUCTS TECHNICIAN. Doing so may void your warranty.**

## 6 MAINTENANCE

### 6.1 General Information

Your TechnoVibe B-Series bowl vibrator has been designed to require an absolute minimum of maintenance effort. However, the ability of the unit to deliver long, trouble free service will depend on the amount of general care and attention that it receives. As the machine relies on the creation of vibration to complete its task, it is essential that regular checks be made to ensure that all is well - particularly in the area of motor bearings and general fixing screws etc.

### 6.2 Motor

Refer to the *Motor Installation and Maintenance Manual* included at the end of this manual for exact details on the maintenance of the vibratory motor applicable to your TechnoVibe B-Series bowl vibrator.

If the motor should require any form of maintenance it should be removed and returned to the point of original purchase. With motor stopped - Check (occasionally) by correct size wrench on locknuts under motor mounting plate that fixing screws and grease line fittings (if fitted) have not worked loose through vibration.

### 6.3 Fastenings

**Weekly** - Check all visible fixings - screws, nuts, etc. to ensure that none have worked loose through vibration. Tighten fixings where necessary.

**Monthly** - Check that motor cables are properly clamped in their cable glands. Tighten gland pinch nuts if necessary. Cable glands are easily reached via weight access routes.

## **7 SUPPLIES, SPARES AND SERVICE**

For Media and/or Compound Supplies, Spare Parts, Maintenance and/or Operational advice please contact your nearest B.V. Products company or B.V. Products accredited agent.

Please remember that an extended warranty time if applicable (3 years from date of supply) against undue wear of the work chamber, is dependant on the exclusive use of processes and consumables supplied and approved by the B.V. Products companies or accredited agents.

8 DRAWING – Pictorial General Assembly & Sound Lid

ISS	DATE.	CHANGE.	SIGN.		ITEM	DESCRIPTION	QTY
					1	SPRAY HEAD (USE DRILL-JIG)	1
					2	RISER 48mm LONG.	1
					3	90° ELBOW/Q.A.VALVE.	1
					4	HOSE TAIL.	1
					5	1/2" LINE TEE.	1
					6	RISER 35mm LONG.	1
					7	1/2" BLACK CAP.	1
					8	HOSE - 800mm LONG W/ CLAMPS	1
					9	JUNCTION BOX H.P.B.J170.	1
					10	BV CURVE CORRECTOR.(JIG-DRILL)	1
					11	10GA X 25 STS SCREWS.	4
					12	NG15 CABLE GLAND.	1
					13	TERMINAL STRIP.	1
					14	SERIAL NO.PLATE.	1
					15	BV LOGO	1

\* Q.A.VALVE NOT REQUIRED FOR UKM/C'S

NOTE: MACHINES WITH LIDS REQUIRE TESA TAPE UNDER HINGED SECTIONS.

ALL VENTS FITTED TO LIDS WITH 10GA. X 3/4" ST.ST. SCREWS.

TITLE	<b>B.V. Products (Australia) Pty. Ltd.</b> 14 Brett Drive, Carrun Downs, Vic.3501 Phone: (03) 9775 0898 Fax:(03) 9775 0897	DRAWN BY	PRS	SCALE	N.T.S.
BV4B ASSEMBLY NOTES		CHECKED BY		DRAWING NO. :	BV4B
		DATE	21/12/99		

Main component parts - TechnoVibe B-Series bowl vibrator

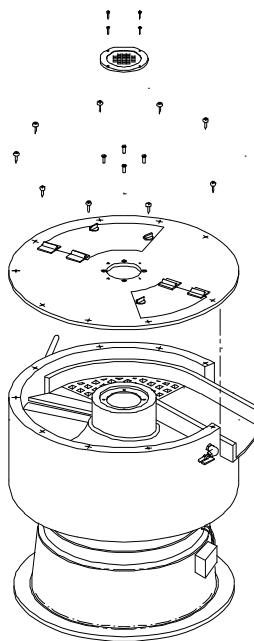

TechnoVibe bowl vibrator with lid (if supplied)

9 MOTOR DETAILS

# SFK 16 TO 60

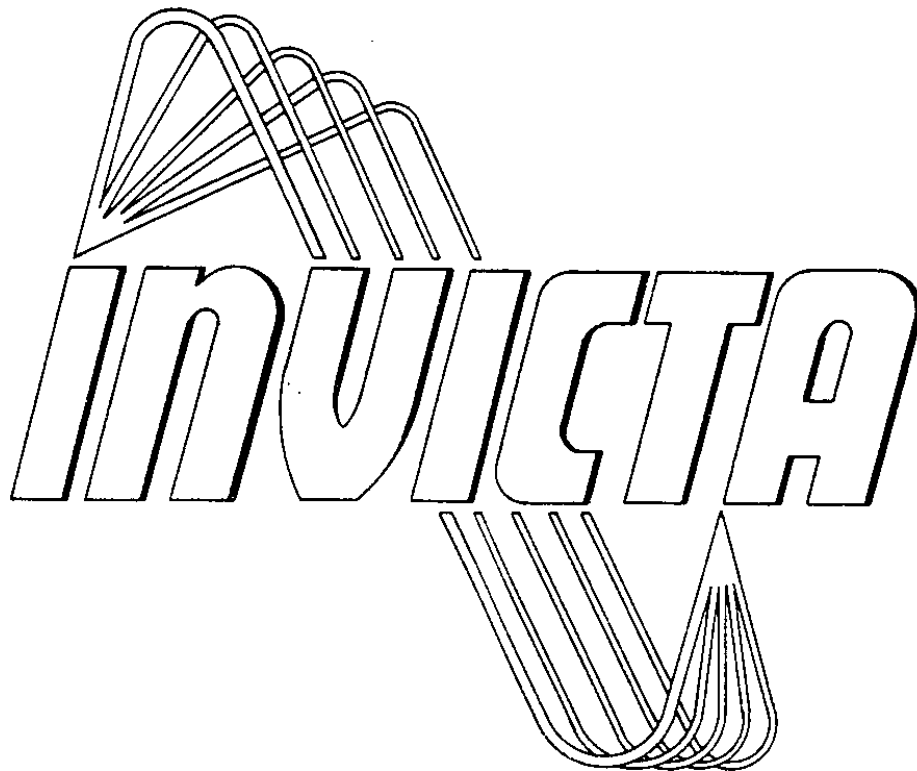

## INSTALLATION AND MAINTENANCE 'SFK' SERIES VIBRATORS - SINGLE FLANGE

**INVICTA VIBRATORS**  
A Division of Grantham Engineering Limited

Harlaxton Road, Grantham,  
Lincolnshire, ENGLAND NG31 7SF

Telephone: +44 (0) 1476 566301  
Fax: +44 (0) 1476 590145

**'K' SERIES VIBRATOR INSTALLATION AND MAINTENANCE**

**RECEIPT AND STORAGE**

Every vibrator is tested and inspected on completion. Whilst every care is taken during transit they should be inspected on receipt and any defects immediately reported to the carrier and supplier. When not for immediate use, they can be stored for upto two years if kept in a clean, dry and temperate atmosphere free of vibration. Grease should be renewed after long storage.

**INSTALLATION GUIDANCE NOTES:**

**Mechanical** Inspect vibrator for any physical damage and check that rotor shaft rotates freely. ALL mounting surfaces MUST be free of paint, dirt and scale. Fixing bolts should be tightened as recommended below and tightness checked after initially running the vibrator. Bolts and nuts should not be reused.

Use Grade 8.8 bolts with Grade 8 "Polystop" nuts, torqued to values below. Figures apply with lightly oiled threads.

Torque (N.m) Cap- Setscrews			Torque (N.m) Cap- Setscrews			Torque (N.m) Capscrews/ Setscrews		Torque (N.m) Capscrews/ Setscrews	
Size	Screws	/Bolts	Size	Screws	/Bolts	Size	Size	Screws	Screws
M 5	8	-	M 12	127	96	M 5	M 12	6.5	96
M 6	15	11	M 16	310	242	M 6	M 16	11	176
M 8	34	27	M 20	-	473	M 8	M 24	27	490
M 10	68	56	M 24	-	818	M 10		56	

Use the above figures for all screws except out of balance weights.

Use the above figures for out of balance weights only.

**Electrical** Check insulation resistance and if less than 1 megohm DO NOT USE, consult a qualified electrician.

Flexible cable and suitable cable gland must be used to connect between vibrator and supply junction box. Supply must be suitably fuse protected. 4 core cable to be used with flexible conductors type 50/0.25 (SFK 16-SFK 40), 56/0.30 (SFK 50) and 80/0.40 (SFK 60). SFK 26 to SFK 60 are fitted with thermistors as standard and require a 2 core cable with flexible conductors type 30/0.25. Flexible conductors must be terminated with crimp on ring terminals for L1, L2, L3 and earth and plain soldered ends for thermistor connections T1 and T2. If thermistors are not required leave the blanking plug in the cable entry hole. Electrically suitable non-setting compound to be packed around leads in terminal and junction boxes to prevent damage through vibration. Starting can be direct on line, via inverter or soft start. Each vibrator MUST BE INDIVIDUALLY PROTECTED against overload.

**FULL LOAD AND STARTING CURRENTS IN AMPS FOR SFK SERIES VIBRATORS  
230-500 VOLTS, 3 PHASE, 50 HERTZ Maximum Figures for 40°C Ambient**

Type	Output Watts	230 Volts		240 Volts		380 Volts		400 Volts		415 Volts		500 Volts	
		FLC	SC	FLC	SC	FLC	SC	FLC	SC	FLC	SC	FLC	SC
<b>2 POLE - 2880 RPM</b>													
SFK 16, SFK 21	340	1.44	4.96	1.38	4.75	0.87	3.0	0.83	2.85	0.80	2.75	0.67	2.28
SFK 26	510	2.07	7.22	1.98	6.92	1.26	4.37	1.19	4.15	1.15	4.0	0.95	3.32
SFK 30	1100	4.0	30	3.8	28	2.4	18	2.3	17	2.2	16	1.9	14
<b>4 POLE - 1440 RPM</b>													
SFK 16, SFK 21	250	1.89	3.88	1.81	3.72	1.15	2.35	1.09	2.23	1.05	2.15	0.87	2.08
SFK 26 ALL	500	2.71	9.38	2.60	9.0	1.64	5.68	1.56	5.39	1.5	5.2	1.25	4.32
SFK 30 ALL	960	4.4	45	4.2	43	2.6	27	2.5	26	2.4	25	2	21
SFK 40	1800	7.8	73	7.5	70	4.7	44	4.5	42	4.3	40	3.6	34
SFK 50-45, -55	3350	11.1	106	10.7	102	6.7	64	6.4	61	6.2	59	5.2	49
SFK 50-75	4800	15.7	148	15	142	9.5	89	9	85	8.7	82	7.2	68
SFK 60	7750	24.0	268	23	257	14.5	162	13.8	154	13.3	148	11	123
<b>6 POLE - 960 RPM</b>													
SFK 26 ALL	500	3.70	8.66	3.54	8.30	2.24	5.24	2.13	4.98	2.05	4.80	1.70	3.98
SFK 30 ALL	900	5.2	32	5	31	3.2	19	3	18.4	2.9	17.7	2.4	14.8
SFK 40	1300	7.0	44	6.7	43	4.2	27	4	25.5	3.8	24	3.2	21
SFK 50 ALL	4000	15.3	125	14.7	120	9.3	76	8.8	72	8.5	69	7	58
SFK 60	6200	22.8	268	21.8	227	13.8	143	13.1	136	12.6	131	10.5	109

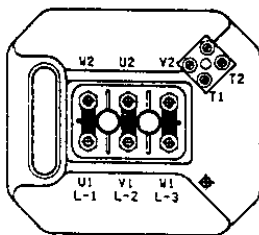

**VIBRATOR TERMINAL BOX field connection**  
3 Phase, 50 Hertz  
DELTA - 220/240V

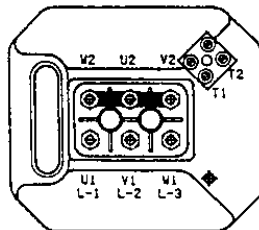

STAR - 380/415V

**OUT OF BALANCE WEIGHT ADJUSTMENT**  
When adjusting O/B weights slacken screw in INNER weight only. Adjust inner weight to required force on percentage scale and retighten screw to torque figures above.

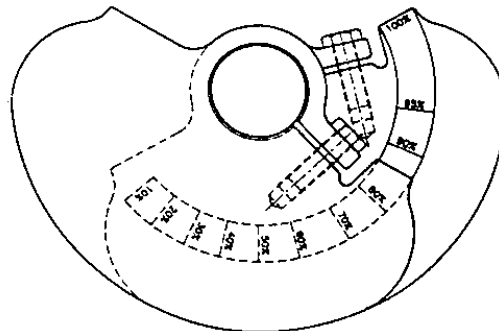

**MAINTENANCE**

Re-Lubrication SFK 16, SFK 21 plus SFK 26-7.5/4 is fitted with shielded ball bearings and is greased for life. SFK 26 (except above) to SFK 30, remove end cover, circlips and out of balance weights (noting position of weights to keep the same force output on re-assembly). Remove bearing cap and bearing housing with bearing outer race. The inner race remains on the rotor shaft. Provided the bearing and grease are in good condition add new grease by lightly smearing it onto the rollers and reassemble

SFK 40 - 60 has grease nipples fitted as standard (which can be removed for piping to external sources). Recommended grease is ESSO UNIREX N3. Do not mix greases without first checking with supplier that they are compatible. Ensure that grease nipples are clean to prevent contamination. Over greasing causes overheating of the bearings and must be avoided. Grease cavities should never be filled above one third of their capacity. It is essential that periodically old grease is removed and the bearings cleaned and repacked with new grease. Normal Duty is operation of up to 12 hours/day at up to 25°C ambient in a relatively clean environment. Severe Duty is operation in one or more of:- Operation above 12 hours/day, above 25°C ambient and dirty environment. Since operation conditions vary considerably the data is provided as a guide only and should be modified as necessary based on service experience.

**GREASING INSTRUCTIONS - 50 HZ. RELUBRICATION CHART**

Type	Relube Interval (Hours)		Per Bearing Relube Amount Gms		BEARING TYPES: It is important that full designation is quoted to ensure that all special features are incorporated.	FAG	SFK
	Normal	Severe	Initial	Fill			
SFK 16-3.5/2	-	-	-	-	6306 2Z C3		
SFK 21-5/2	-	-	-	-	6308 2Z C3		
SFK 26-8/2	-	-	-	-	6309 2Z C3		
SFK 26-13/2	1200	900	7	22	NJ 2307E	TVP2 C3	CPC3
SFK 30-16/2	800	600	9	38	NJ 2309E	TVP2 C3	CPC3
SFK 16-3/4	-	-	-	-	6305 2Z C3		
SFK 21-5/4	-	-	-	-	6307 2Z C3		
SFK 26-7.5/4	-	-	-	-	6309 2Z C3		
SFK 26-11/4	3100	2500	5	17	NJ 2306E	TVP2 C3	CPC3
SFK 26-14/4	2500	2100	7	22	NJ 2307E	TVP2 C3	CPC3
SFK 30-18/4	2100	1800	11	38	NJ 2309E	TVP2 C3	CPC3
SFK 30-25/4	2100	1800	11	38	NJ 2309E	TVP2 C3	CPC3
SFK 40-35/4	1500	1200	16	65	NJ 2311E	TVP2 C3	CPC3
SFK 50-45/4	1200	900	30	210	NJ 2315E	TVP2 C3	CPC3
SFK 50-55/4	1100	800	30	210	NJ 2315E	TVP2 C3	CPC C3
SFK 50-75/4	800	350	30	210	NJ 2317E	M/A C3	CMA C3
SFK 60-95/4	700	300	43	250	NJ 2320E	M/A C3	CMA C3
SFK 26-8/6	4700	4500	6	17	NJ 2306E	TVP2 C3	CPC3
SFK 26-11/6	4000	3700	7	22	NJ 2307E	TVP2 C3	CPC3
SFK 30-14/6	3400	3000	11	38	NJ 2309E	TVP2 C3	CPC3
SFK 30-18/6	3400	3000	11	38	NJ 2309E	TVP2 C3	CPC3
SFK 40-27/6	2300	2000	16	65	NJ 2311E	TVP2 C3	CPC3
SFK 50-42/6	1900	1600	30	150	NJ 2315E	TVP2 C3	CPC3
SFK 50-60/6	1900	1600	30	150	NJ 2315E	TVP2 C3	CPC3
SFK 50-75/6	1500	1200	38	210	NJ 2317E	TVP2 C3	CPC3
SFK 60-105/6	1200	900	53	250	NJ 2320E	TVP2 C3	CPC3

**REMOVAL AND FITTING OF BEARINGS: 26 - 60 (except 26-8/2, -7.5/4):** Bearings should only be removed when absolutely necessary. Extractor tools should be used to remove the outer race, cage and rollers from the bearing housing and the inner race from the rotor shaft. If the same bearings are to be used again, wash them thoroughly in a mixture of petrol and light machine oil. Replacement bearings must have the special features recommended - See above. When refitting bearings, smear inside recess in housing with grease, lightly pack the outer race and rollers with grease, forcing some well into the workings parts. Since some of the interference fit can be lost by removing and fitting new bearings they should always be re-fitted using Loctite 648 or equivalent. Refit into the housing using either a small press or a soft metal drift and hammer. The inner race of the bearing should be placed in a bath of clean mineral oil and heated to a temperature of 80°C (180°F). The race should be pushed into place and held against the shaft shoulder until it contracts sufficiently to grip the shaft. Place the rotor carefully inside the stator bore and fit bearing housings, weights and end cover. Use Loctite 242 (or equivalent) on screws when refitting bearing housing and cap. Check that the rotor shaft has correct float.

SFK 26-8/2, -7.5/4 has shielded ball bearings and should be replaced if damaged.

**FAULT FINDING - VIBRATORS**

1. **Vibrator does not start or fails to run.**  
 Provided that supply voltage is present at the vibrator terminal box check the following:
  - a) Supply voltage is correct and starter is operating correctly.
  - b) All three phases of supply voltage are connected and the brass links in the vibrator terminal box are present and in correct position for supply voltage.
  - c) Vibrator is clear of "earth" faults and the stator winding is not open circuit in any one phase and no short circuits exist between adjacent turns.
  - d) Vibrator is not overloaded electrically or mechanically (See 2).
2. **Vibrator current exceeds rated full load current or overheats Check:**
  - a) That vibrator fixing bolts are correctly tightened and there is no damage to end covers preventing weights rotating.
  - b) Bearings are not partially seized or over greased.
  - c) Out of balance weights are not set at too great a force output.
3. **Vibrator Noisy**  
 NOTE Due to the increased radial clearance in the bearings it is normal for vibrators to emit a certain amount of noise and they should not be compared with standard electric motors. Check:
  - a) That there are no loose parts on the vibrator.
  - b) End covers are not damaged and fouling out of balance weights.
  - c) Noise is not due to bearing failure.
4. **Vibrator(s) does(do) not attain synchronous speed Check:**
  - a) That the vibrator is not wrongly connected (star instead of delta)
  - b) Supply voltage and supply frequency are not too low.
  - c) Vibrator is not overloaded or partially seized.

SECTION SHOWING BREAKDOWN OF MAJOR COMPONENTS FOR SPARES

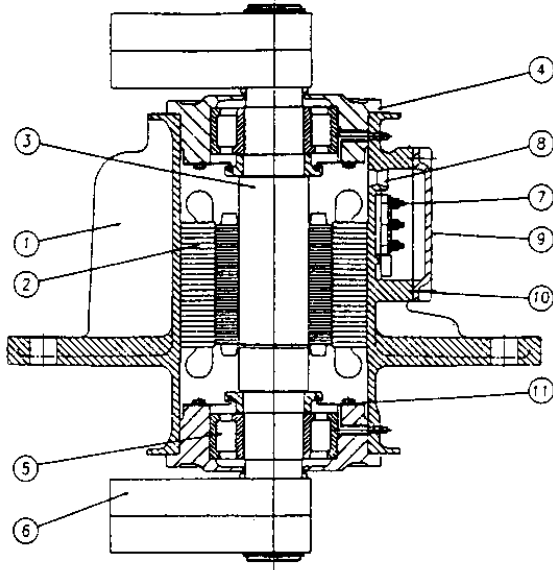

SFK 30 - 60

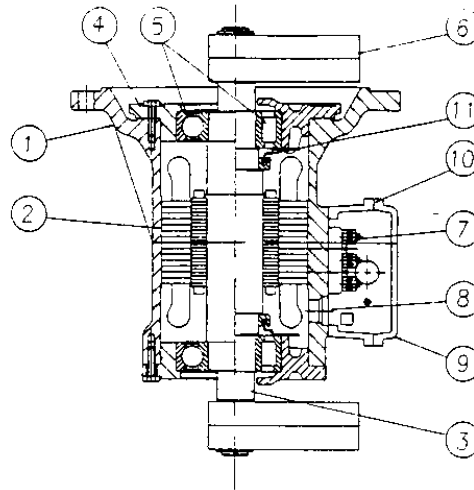

SFK 16,21      SFK 26-13/2, -11/4,  
& 26-8/2, -7.5/4      14/4, -8/6 & -11/6

Component		PARTS LIST		Component	
1	Stator frame	1		7	Terminal block
2	Stator unit	1		8	Grommet
3	Rotor shaft assembly	1		9	Terminal box lid
4	Bearing housing	2		10	Terminal box lid gasket
5	Bearing	2		11	Grease Shield
6	O/B Weight assembly	1			

All Hex. head screws are grade 8.8 and socket screws grade 12.9.

Quote vibrator type, serial number, voltage, together with part description when ordering spares

EC DECLARATION OF CONFORMITY

Invicta rotary out of balance electric vibrators meet with the essential Protection Requirements of the E.M.C. Directive Council Directive 89/336/EEC and have been type tested by:

E.R.A. Technology Limited, Cleeve Road, Leatherhead, Surrey. KT 22 7SA



to EN 50081 - 1 : 1992 Electromagnetic Compatibility:  
Residential, Commercial and Light Industrial

E.R.A. Test Report 5044/6N4/1

Technical construction file TCF/1K/00a forwarded to E.R.A. Technology and covered by their competent body report E.R.A. Report 4473/1A1

Invicta rotary out of balance electric vibrators conform to the requirements of the Low Voltage Directive 73/23/EEC

E.C. DECLARATION OF INCORPORATION

AN INVICTA ROTARY OUT OF BALANCE ELECTRIC VIBRATOR MUST NOT BE PUT INTO SERVICE UNTIL THE MACHINERY INTO WHICH IT IS TO BE INCORPORATED HAS BEEN DECLARED IN CONFORMITY WITH THE PROVISIONS OF:

"THE SUPPLY OF MACHINERY (SAFETY) REGULATIONS 1992 (51 1992/3073)

*Lw Blankley*

L. W. Blankley - Technical Director

The information contained in this booklet is issued as a guide and is not intended to be definitive. No legal liability shall attach to Grantham Engineering Limited in connection with the use of this Guide. Users of the machine are reminded that all work must comply with existing regulations imposed by statute or by regulatory authorities, and it is the users responsibility to ensure compliance with such Regulations.  
P 1906, Issue A (04.03.1997)